



Identification and Overview

BAPI's Echelon® compatible "L-Temp" Room Unit features measurement and display of local temperature (°C or °F), as well as display of outdoor temperature and outdoor humidity – all in one aesthetically-pleasing package.

An onboard Neuron® chip allows connection directly to a LonWorks® network using star, bus, or loop topology. Additional options include Temperature Setpoint and Local Override as well as Fan Speed Control for Fan Coils, Heat Pumps, Unit Ventilators or other Terminal Units. The Fan Speed is provided as a Network Variable and includes appropriate LCD Indicators.

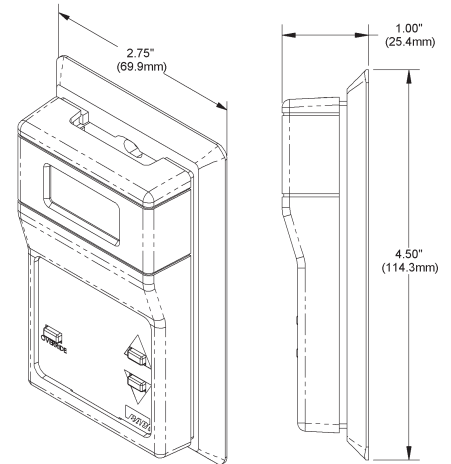

Fig. 1:
L-Temp (BA/LC-RSOD)
LON Sensor w/Display,
Setpoint & Override

Mounting

JUNCTION BOX

1. Pull the wire through the wall and out of the junction box, leaving about 6" free.
2. Pull the wire through the hole in the base plate and secure the base to the box using the #6-32 x 1/2 inch mounting screw provided.
3. Terminate the unit according to the guidelines in the Termination Section.
4. Attach Cover by latching it to the top of the base, rotating the cover down and snapping it into place. Secure the cover by backing out the lock-down screws using a 1/16" Allen wrench until they are flush with the bottom of the cover.

DRYWALL MOUNTING

1. Place the base plate against the wall where you want to mount the sensor. Use a pencil to mark the two mounting holes and the hole for the wires on the wall.
2. Drill the two 3/16" mounting holes and insert a drywall anchor into each hole.
3. Drill the 1/2" hole for the wires and pull the wire through the wall and out of the 1/2" hole, leaving about 6" free.
4. Pull the wire through the hole in the base plate.
5. Secure the base to the drywall anchors using the #6 x 1 inch mounting screws provided.
6. Terminate the unit according to the Termination guidelines in on pg 2.
7. Attach Cover by latching it to the top of the base, rotating the cover down and snapping it into place.
8. Secure the cover by backing out the lock-down screws using a 1/16" Allen wrench until they are flush with the bottom of the cover.

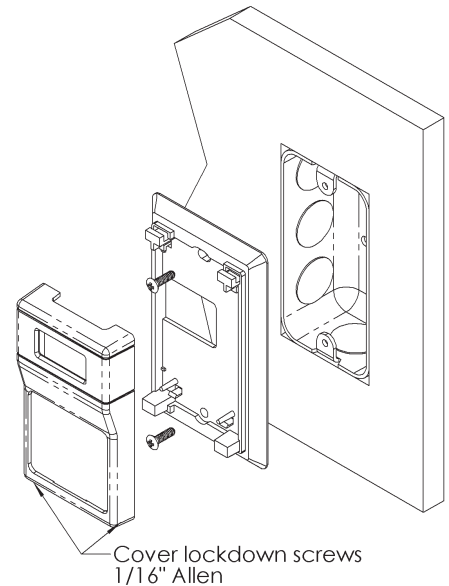

Fig. 2: Delta Room Sensor installation
Hardware for J-box or direct drywall
mount provided.

NOTE: In a wall-mount application, the wall temperature and the temperature of the air within the wall cavity can cause erroneous readings. The mixing of room air and air from within the wall cavity can lead to condensation, erroneous readings and premature failure of the sensor. To prevent these conditions, seal the conduit leading to the junction box.

Wiring & Termination

BAPI recommends using twisted pair of at least 22AWG and sealant filled connectors for all wire connections. Larger gauge wire may be required for long runs. All wiring must comply with the National Electric Code (NEC) and local codes. Do NOT run this device's wiring in the same conduit as AC power wiring.

For additional wiring information and requirements, please refer to Echelon® Corporation's Bulletin titled "Junction Box and Wiring Guidelines for Twisted Pair LonWorks® Networks" which can be found online at the following URL. <http://www.echelon.com/support/documentation/Bulletin/005-0023-01K.pdf>



BAPI recommends wiring the product with power disconnected. Proper supply voltage, polarity, and wiring connections are important to a successful installation. Not observing these recommendations may damage the product and will void the warranty.

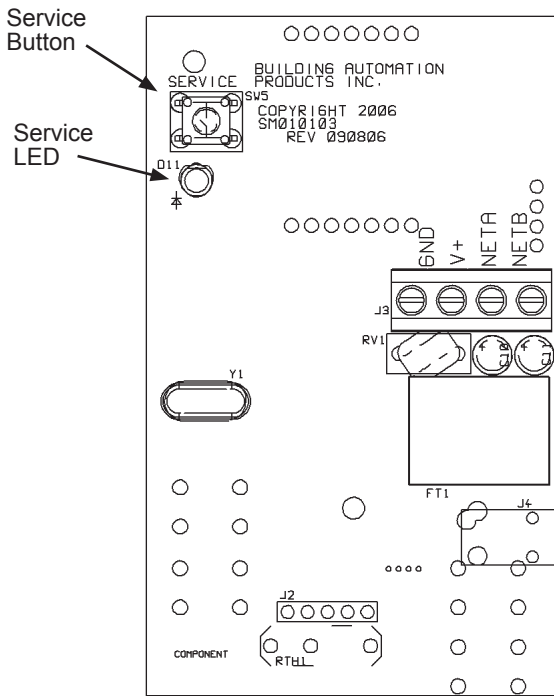

Terminal Description

- NETBNetwork B
- NETANetwork A
- V+8 to 24VDC or 12 to 28VAC
- GND.....Power Supply Ground

Fig. 3: Termination & Board layout

Communication Jack Termination

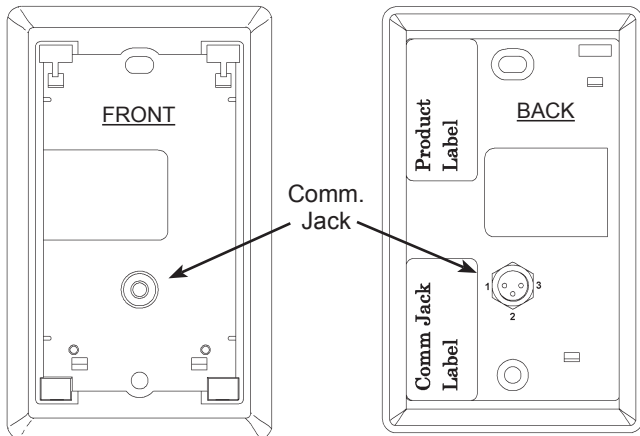

Fig. 4: Comm. Jack Location

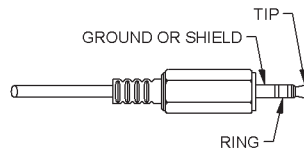

Fig. 5: 3.5mm Stereo Jack Pins

C35 Communication Jack Option		
Plug ID	Wire Color	Pin #
Ground	Black	1
Tip	White	2
Ring	Red	3

Table 1: C35 Wiring ID

Specifications subject to change without notice.



Controls and Indication

Occupant Controls (See Fig. 1)

- Display LCD: Shows the temperature that is sent out on “nvoHVACTemp”
- Override Button: Pushing this button activates “nvoOccupancy”
- Setpoint Buttons: Up and down buttons activate “nvoTempSP”

Technician Controls (See Fig. 3)

- Service Button: The service button on the upper left of the board is used to request communication with the main computer over the network.
- Service LED: The LED flashes when the unit is first turned on and still needs commissioning.
 The LED is off when commissioned and is ready for use.
 The LED flashes on a “Wink” request.

Network Variable Listing and Definitions

Current External Interface File (XIF), Neuron® Executable File (NXE) and/or Application Binary File (APB) files can be downloaded for www.bapihvac.com under the “Temperature” tab for the Room sensors, L-Temp & L-Combo.

<u>Network Variable</u>	<u>SNVT Type</u>	<u>Description</u>
nviRequest	SNVT_obj_request	[Request information from sensor]
nvoStatus	SNVT_obj_status	[Status information from sensor]
nvoHVACTemp	SNVT_temp_p	[Temperature Output]
nciMaxSendTime	SNVT_time_sec	[Maximum amount of time before nvoHVACTemp is updated]
nciMinSendTime	SNVT_time_sec	[Minimum amount of time before nvoHVACTemp is updated]
nciMinDelta	SNVT_Temp_p	[Minimum change in temperature that must be observed in order for information to be sent to the network]
nciTmpOffset	SNVT_temp_p	[Temperature Offset]
nviTempSP	SNVT_Temp_p	[Temperature setpoint sent from network to sensor]
nvoTempSP	SNVT_temp_p	[Temperature setpoint sent from sensor to network]
nciTempSPlo	SNVT_Temp_p	[Minimum Temperature Setpoint]
nciTempSPhi	SNVT_temp_p	[Maximum Temperature Setpoint]
nviOccupancy	SNVT_occupancy	[Occupancy variable sent from network to sensor]
ncist_bits	SNVT_state	[bit 0 = Degree Setting for LCD, 1 = °C, 0 = °F bits 1 to 15 = reserved for future use]

Specifications

Supply Voltage: 8 to 24VDC (recommended) or 12 to 28VAC	Wiring: 4 wire, twisted pair 22 AWG min.
Power: 35 mA maximum DC	Communication: Neuron® 3120®, 78 kbps using FTT-10A transceiver
Sensing Elements: Temperature Semiconductor Band Gap, Proportional to Absolute, ±0.3°C Opt. Humidity Capacitive Polymer, ±1.8%RH Accuracy	Mounting: 2x4” J-box or drywall mount Mounting screws provided
Options: Display (D) 0.4”, 3.5 digit, LCD Setpoint (S) 2-Pushbuttons, Up & Down Override (O) Pushbutton Fan (XLD) Pushbutton (Includes display, setpoint and override)	Ambient: Temperature 32 to 122°F (0 to 50°C) Humidity 0 to 95%, non-condensing
Comm. Jack 3.5mm stereo jack, add 3 wires	Material: ABS Plastic Material Rating: UL 94, V-0 Range: -40°C to 85°C Agency: RoHS

Specifications subject to change without notice.